

## Ô~ !!^} oÁ^} • [ !

T [ â^|Á~ { à^!:

- AN1V 50 PB31
- AN1V 100 PB31
- AN1V 150 PB31
- AN1V 200 PB31

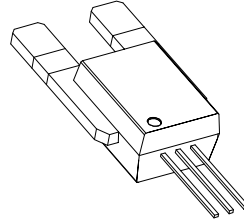

For the electronic measurement of current:DC,AC,pulsed...,with galvanic separation between the primary and the secondary circuit.

### Features

- ◇ Open loop current sensor using the Hall effect
- ◇ ASIC Technology
- ◇ Supply voltage 3.3V
- ◇ Maintain output proportional to changes in the power supply (include offset and sensitivity)
- ◇ Galvanic separation between primary and secondary
- ◇ Insulating plastic case recognized according to UL 94-V0
- ◇ No insertion losses
- ◇ Small size
- ◇ Standards:
  - IEC 60664-1:2020
  - IEC 61800-5-1:2022
  - IEC 62109-1:2010

### Applications

- ◇ AC variable speed
- ◇ Uninterruptible Power Supply (UPS)
- ◇ Static converters for DC motor drives
- ◇ Switch Mode Power Supplies (SMPS)
- ◇ Power supply for welding applications
- ◇ Battery Management
- ◇ Wind energy inverter

### Safety

The sensor must be used according to IEC 61800-5-1. The sensor must be used in electric/electronic equipment with respect to applicable standards and safety requirements in accordance with the following manufacture's operating instructions.

**Caution,risk of electrical shock !**



When operating the sensor, certain parts of the module can carry hazardous voltage (e.g., Primary busbar,power supply). Ignore this warning can lead to injury and/or cause serious damage.

This sensor is a built-in device, whose conducting parts must be inaccessible after installation. A protective housing or additional shield could be used.

Main supply must be able to be disconnected.

# AN1V PB31

## Absolute maximum ratings(not operating)

Parameter	Symbol	Unit	Value
Supply voltage	$V_C$	V	6.5
ESD rating, Human Body Model (HBM)	$V_{ESD}$	V	8000

※ Stresses above these ratings may cause permanent damage.

※ Exposure to absolute maximum ratings for extended periods may degrade reliability

## Environmental and mechanical characteristics

Parameter	Symbol	Unit	Min	Typ	Max	Comment
Ambient operating temperature	$T_A$	°C	-40		150	AN1V 50 PB31
			-40		150	AN1V 100 PB31
			-40		125	AN1V 150 PB31
			-40		85	AN1V 200 PB31
Ambient storage temperature	$T_S$	°C	-55		150	
Primary resistance value	$R_P$	$\mu\Omega$		100		
Mass	$m$	g		5		

## Insulation coordination

Parameter	Symbol	Unit	Value	Comment
Rms voltage for AC insulation test@ 50Hz,1min	$V_d$	kV	4.8	According to IEC 60664-1
Plastic case	-	-	UL94-V0	
Comparative tracking index	$CTI$	PLC	2	
Application example	-	-	475V <sub>RMS</sub>	Reinforced insulation,According to IEC 61800-5-1, IEC 62109-1CATIII, PD2
Application example	-	-	960V <sub>RMS</sub>	Basic insulation,According to IEC 61800-5-1, IEC 62109-1CATIII, PD2

## Electrical data

### AN1V 50 PB31

※ With  $T_A = 25^\circ\text{C}$ ,  $V_C = 3.3\text{V}$ ,  $R_L = 10\text{k}\Omega$ , unless otherwise noted.

Parameter	Symbol	Unit	Min	Typ	Max	Comment
<b>Electrical data</b>						
Primary nominal rms current	$I_{PN}$	A	-50		50	
Supply voltage	$V_C$	V	3	3.3	3.6	
Output voltage	$V_{OUT}$	V	$V_{OUT} = V_{OV} + G_{th} \times I_P \times (V_C/3.3)$			
Electrical offset voltage	$V_{OV}$	V		$V_{CC}/2$		
Theoretical sensitivity	$G_{th}$	mV/A		26.4		
Current consumption	$I_C$	mA		8	11	
Load resistance	$R_L$	k $\Omega$	5.1			
Load capacitor	$C_1$	nF		1	10	
Power filter capacitor	$C_2$	nF		100		
<b>Performance data</b>						
Sensitivity error	$\varepsilon_G$	%	-1		1	
Temperature of G	$TCG$	%	-1.5		1.5	@ $T_A = -40^\circ\text{C} \sim 150^\circ\text{C}$
Electrical offset current	$V_{OE}$	mV	-10	$\pm 5$	10	@ $V_C = 3.3\text{V}$ also $I_P = 0\text{A}$
Electrical offset error of temperature drift	$TCV_{OE}$	mV	-10		10	@ $T_A = -40^\circ\text{C} \sim 150^\circ\text{C}$
Hysteresis offset voltage	$V_{OM}$	mV		4		@ $V_C = 3.3\text{V}$ , after $\pm I_{PN}$
Linearity error	$\varepsilon_L$	% of $I_{PN}$	-1		1	Exclusive of $V_{OE}$
Accuracy @ $I_{PN}$	$X$	% of $I_{PN}$	-2		2	@ $T_A = -40^\circ\text{C} \sim 150^\circ\text{C}$
Response time@ 90% of $I_{PN}$	$t_r$	$\mu\text{s}$		2.5	5	@ $C_1 = 1\text{nF}$
Frequency bandwidth(-3dB)	$BW$	kHz		250		@ $C_1 = 1\text{nF}$
Output noise	$V_{no}$	mV		2.1		@ $C_1 = 1\text{nF}$

## Electrical data

### AN1V 100 PB31

※ With  $T_A = 25^\circ\text{C}$ ,  $V_C = 3.3\text{V}$ ,  $R_L = 10\text{k}\Omega$ , unless otherwise noted.

Parameter	Symbol	Unit	Min	Typ	Max	Comment
<b>Electrical data</b>						
Primary nominal rms current	$I_{PN}$	A	-100		100	
Supply voltage	$V_C$	V	3	3.3	3.6	
Output voltage	$V_{OUT}$	V	$V_{OUT} = V_{OV} + G_{th} \times I_P \times (V_C/3.3)$			
Electrical offset voltage	$V_{OV}$	V		$V_{CC}/2$		
Theoretical sensitivity	$G_{th}$	mV/A		13.2		
Current consumption	$I_C$	mA		8	11	
Load resistance	$R_L$	k $\Omega$	5.1			
Load capacitor	$C_1$	nF		1	10	
Power filter capacitor	$C_2$	nF		100		
<b>Performance data</b>						
Sensitivity error	$\varepsilon_G$	%	-1		1	
Temperature of G	$TCG$	%	-1.5		1.5	@ $T_A = -40^\circ\text{C} \sim 150^\circ\text{C}$
Electrical offset current	$V_{OE}$	mV	-10	$\pm 5$	10	@ $V_C = 3.3\text{V}$ also $I_P = 0\text{A}$
Electrical offset error of temperature drift	$TCV_{OE}$	mV	-10		10	@ $T_A = -40^\circ\text{C} \sim 150^\circ\text{C}$
Hysteresis offset voltage	$V_{OM}$	mV		4		@ $V_C = 3.3\text{V}$ , after $\pm I_{PN}$
Linearity error	$\varepsilon_L$	% of $I_{PN}$	-1		1	Exclusive of $V_{OE}$
Accuracy @ $I_{PN}$	$X$	% of $I_{PN}$	-2		2	@ $T_A = -40^\circ\text{C} \sim 150^\circ\text{C}$
Response time@ 90% of $I_{PN}$	$t_r$	$\mu\text{s}$		2.5	5	@ $C_1 = 1\text{nF}$
Frequency bandwidth(-3dB)	$BW$	kHz		250		@ $C_1 = 1\text{nF}$
Output noise	$V_{no}$	mV		1.8		@ $C_1 = 1\text{nF}$

## Electrical data

### AN1V 150 PB31

※ With  $T_A = 25^\circ\text{C}$ ,  $V_C = 3.3\text{V}$ ,  $R_L = 10\text{k}\Omega$ , unless otherwise noted.

Parameter	Symbol	Unit	Min	Typ	Max	Comment
<b>Electrical data</b>						
Primary nominal rms current	$I_{PN}$	A	-150		150	
Supply voltage	$V_C$	V	3	3.3	3.6	
Output voltage	$V_{OUT}$	V	$V_{OUT} = V_{OV} + G_{th} \times I_P \times (V_C/3.3)$			
Electrical offset voltage	$V_{OV}$	V		$V_{CC}/2$		
Theoretical sensitivity	$G_{th}$	mV/A		8.8		
Current consumption	$I_C$	mA		8	11	
Load resistance	$R_L$	k $\Omega$	5.1			
Load capacitor	$C_1$	nF		1	10	
Power filter capacitor	$C_2$	nF		100		
<b>Performance data</b>						
Sensitivity error	$\varepsilon_G$	%	-1		1	
Temperature of G	$TCG$	%	-1.5		1.5	@ $T_A = -40^\circ\text{C} \sim 125^\circ\text{C}$
Electrical offset current	$V_{OE}$	mV	-10	$\pm 5$	10	@ $V_C = 3.3\text{V}$ also $I_P = 0\text{A}$
Electrical offset error of temperature drift	$TCV_{OE}$	mV	-10		10	@ $T_A = -40^\circ\text{C} \sim 125^\circ\text{C}$
Hysteresis offset voltage	$V_{OM}$	mV		4		@ $V_C = 3.3\text{V}$ , after $\pm I_{PN}$
Linearity error	$\varepsilon_L$	% of $I_{PN}$	-1		1	Exclusive of $V_{OE}$
Accuracy @ $I_{PN}$	$X$	% of $I_{PN}$	-2		2	@ $T_A = -40^\circ\text{C} \sim 125^\circ\text{C}$
Response time@ 90% of $I_{PN}$	$t_r$	$\mu\text{s}$		2.5	5	@ $C_1 = 1\text{nF}$
Frequency bandwidth(-3dB)	$BW$	kHz		250		@ $C_1 = 1\text{nF}$
Output noise	$V_{no}$	mV		1		@ $C_1 = 1\text{nF}$

## Electrical data

### AN1V 200 PB31

※ With  $T_A = 25^\circ\text{C}$ ,  $V_C = 3.3\text{V}$ ,  $R_L = 10\text{k}\Omega$ , unless otherwise noted.

Parameter	Symbol	Unit	Min	Typ	Max	Comment
<b>Electrical data</b>						
Primary nominal rms current	$I_{PN}$	A	-200		200	
Supply voltage	$V_C$	V	3	3.3	3.6	
Output voltage	$V_{OUT}$	V	$V_{OUT} = V_{OV} + G_{th} \times I_P \times (V_C/3.3)$			
Electrical offset voltage	$V_{OV}$	V		$V_{CC}/2$		
Theoretical sensitivity	$G_{th}$	mV/A		6.6		
Current consumption	$I_C$	mA		8	11	
Load resistance	$R_L$	k $\Omega$	5.1			
Load capacitor	$C_1$	nF		1	10	
Power filter capacitor	$C_2$	nF		100		
<b>Performance data</b>						
Sensitivity error	$\varepsilon_G$	%	-1		1	
Temperature of G	$TCG$	%	-1.5		1.5	@ $T_A = -40^\circ\text{C} \sim 85^\circ\text{C}$
Electrical offset current	$V_{OE}$	mV	-10	$\pm 5$	10	@ $V_C = 3.3\text{V}$ also $I_P = 0\text{A}$
Electrical offset error of temperature drift	$TCV_{OE}$	mV	-10		10	@ $T_A = -40^\circ\text{C} \sim 85^\circ\text{C}$
Hysteresis offset voltage	$V_{OM}$	mV		4		@ $V_C = 3.3\text{V}$ , after $\pm I_{PN}$
Linearity error	$\varepsilon_L$	% of $I_{PN}$	-1		1	Exclusive of $V_{OE}$
Accuracy @ $I_{PN}$	$X$	% of $I_{PN}$	-2		2	@ $T_A = -40^\circ\text{C} \sim 85^\circ\text{C}$
Response time@ 90% of $I_{PN}$	$t_r$	$\mu\text{s}$		2.5	5	@ $C_1 = 1\text{nF}$
Frequency bandwidth(-3dB)	$BW$	kHz		250		@ $C_1 = 1\text{nF}$
Output noise	$V_{no}$	mV		0.9		@ $C_1 = 1\text{nF}$

# AN1V PB31

## Dimensions(Unit mm)

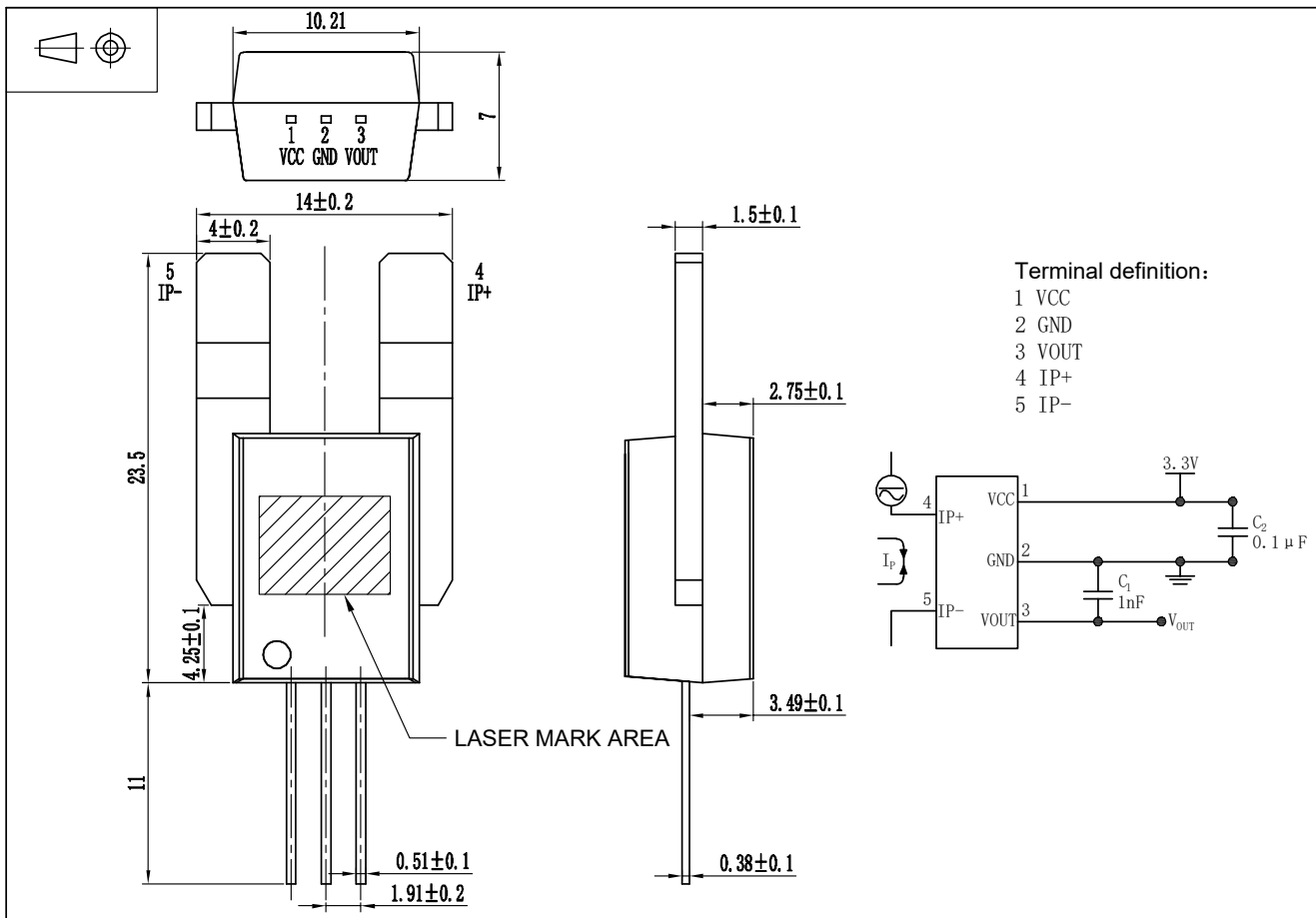

## Mechanical characteristics

- ◇ General tolerance  $\pm 0.3$  mm
- ◇ Conductor and pin material Red copper with tin plating

## Remarks

- ◇ When  $I_p$  flows in the direction of pin4 to pin5,  $V_{out}$  increase.